

01 Coupe longitudinale A-A

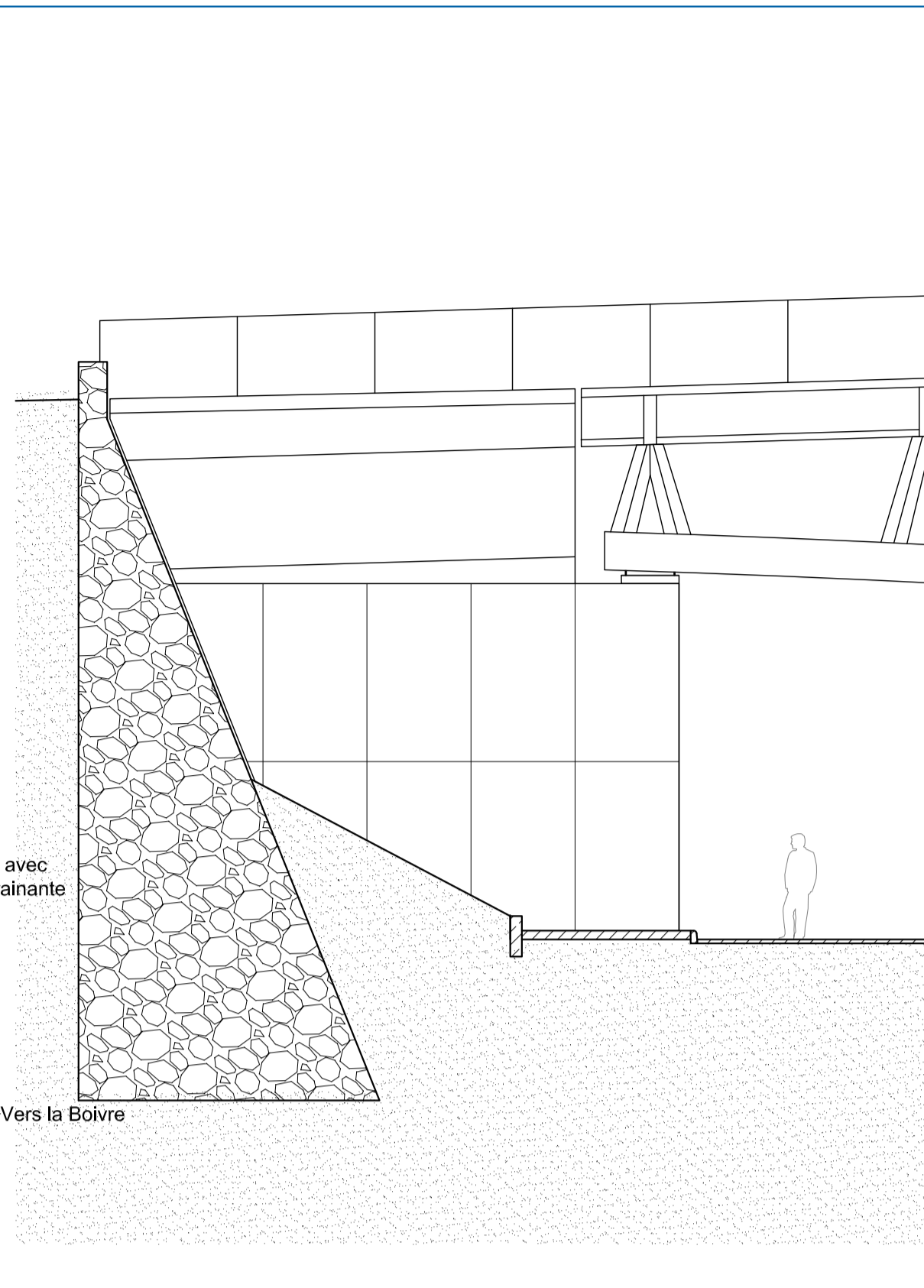

02 Elévation B-B

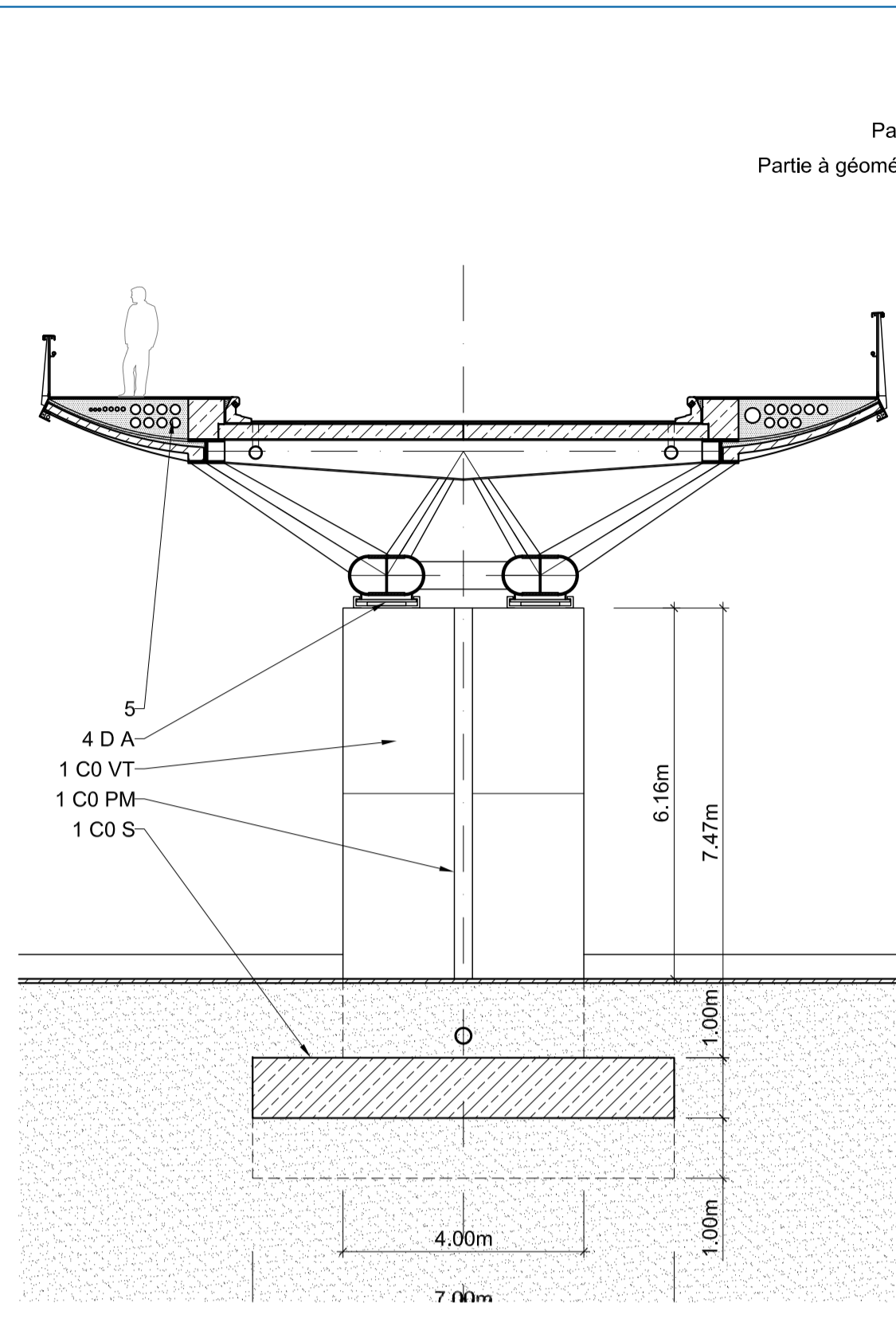

03 Coupe transversale C-C

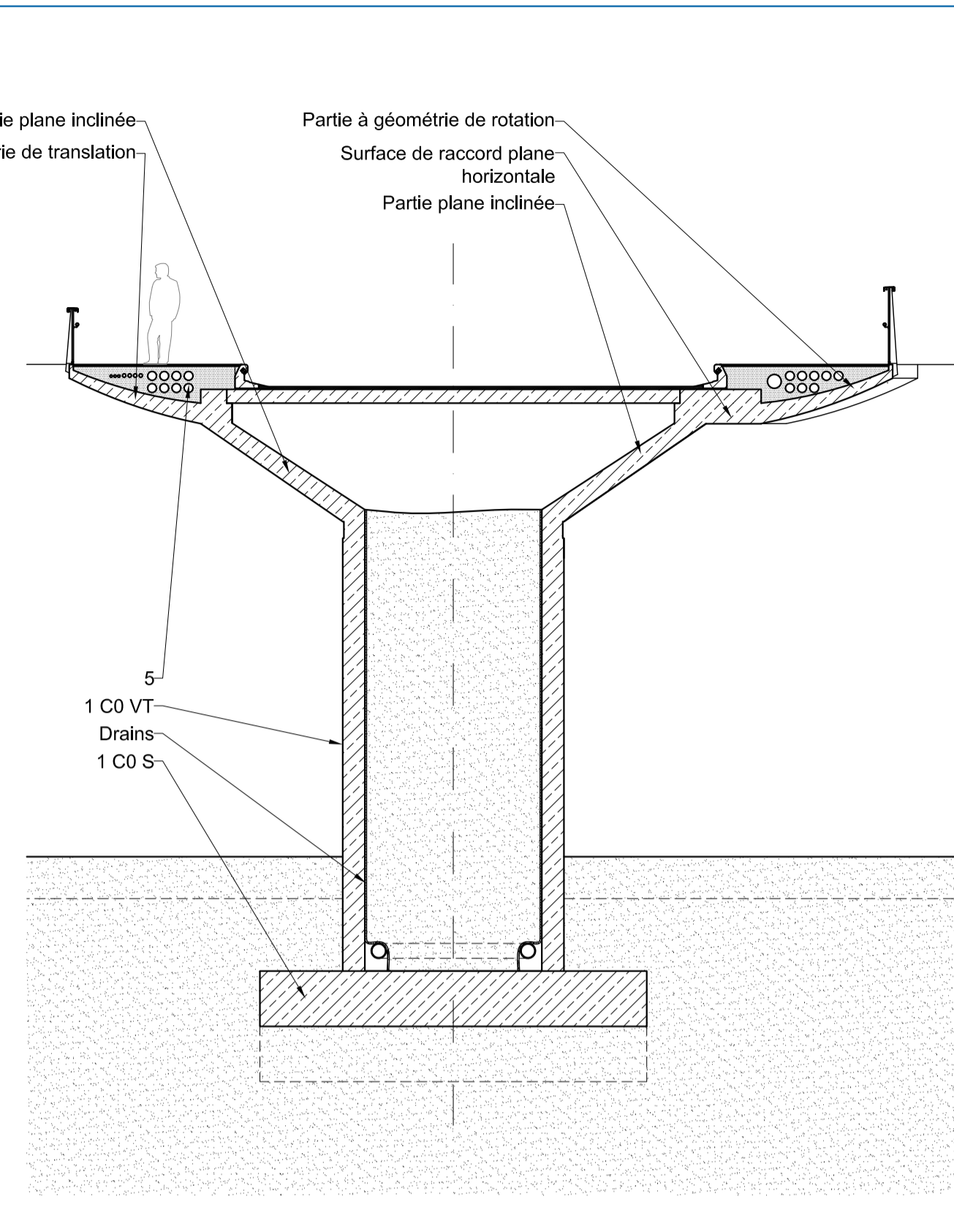

04 Coupe transversale D-D

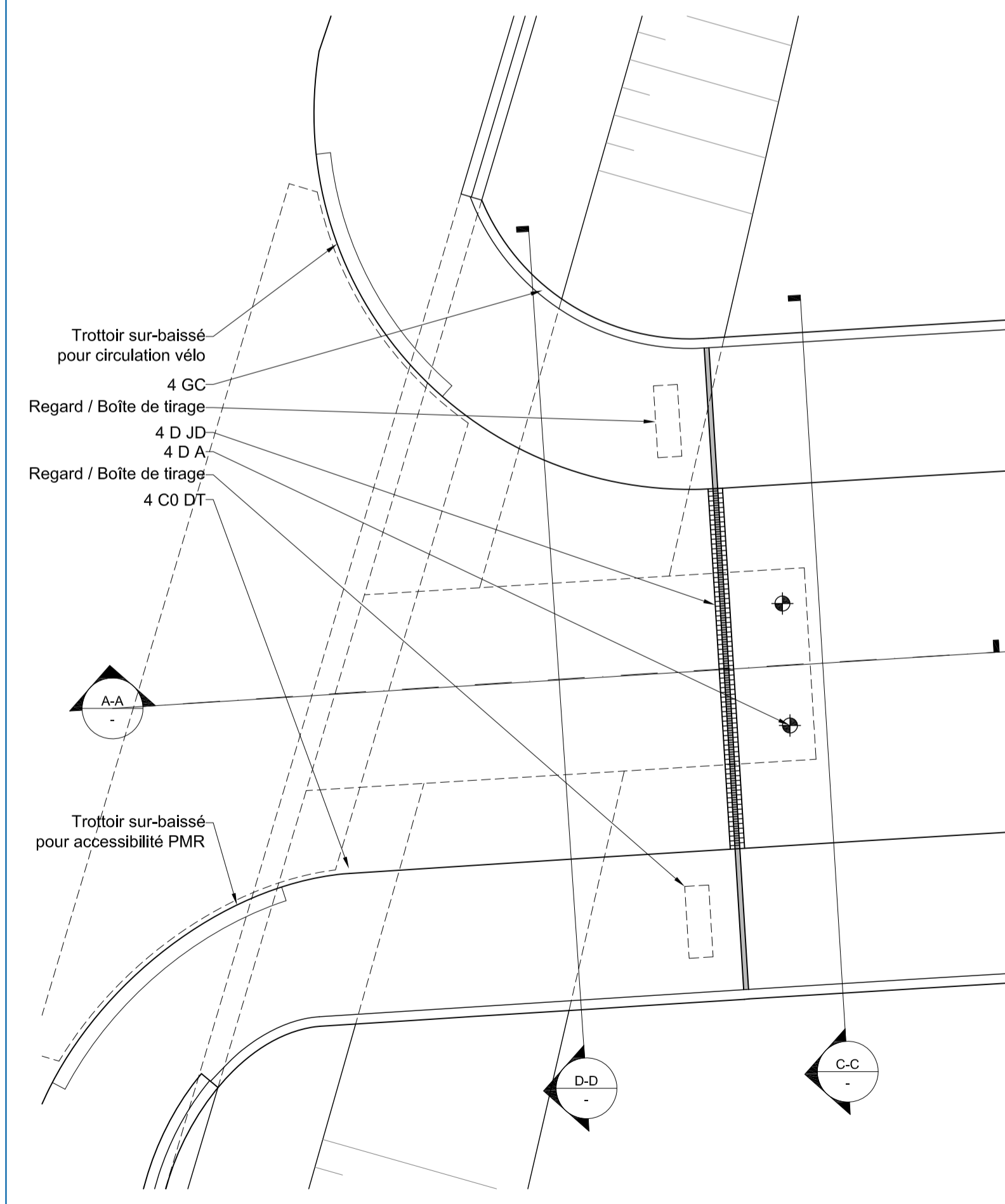

05 Plan de chaussée E-E

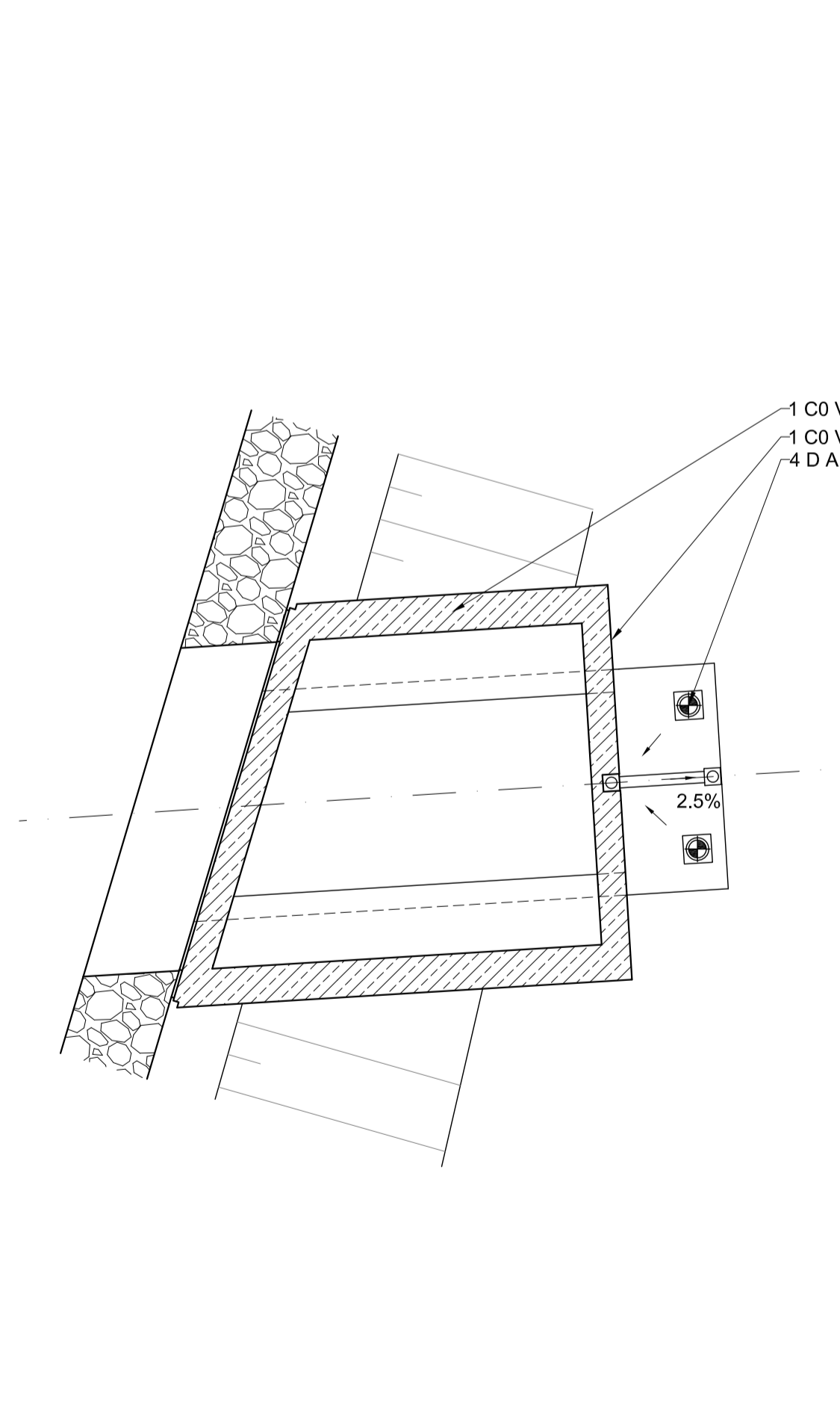

06 Plan des appuis F-F

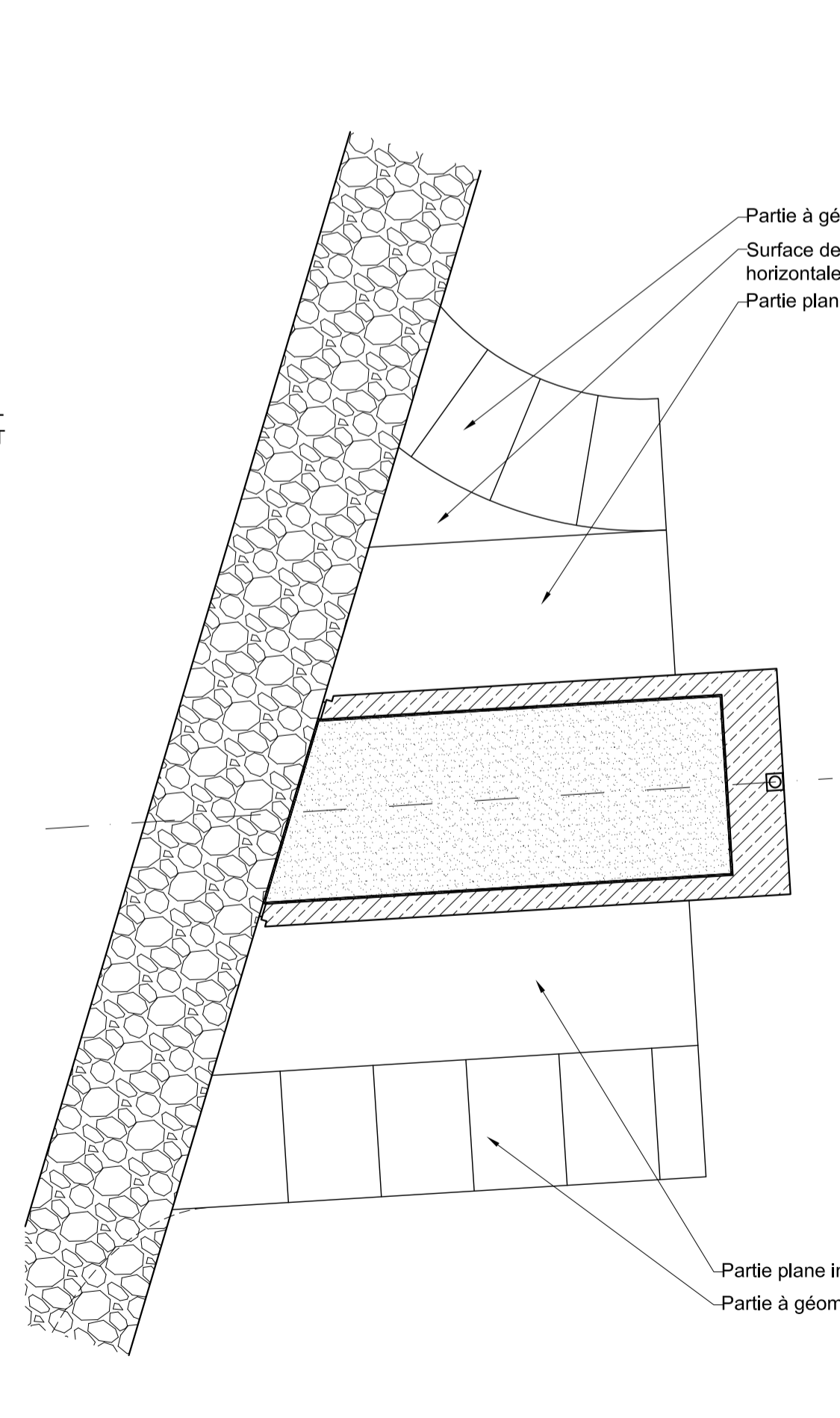

07 Plan de sous-face G-G

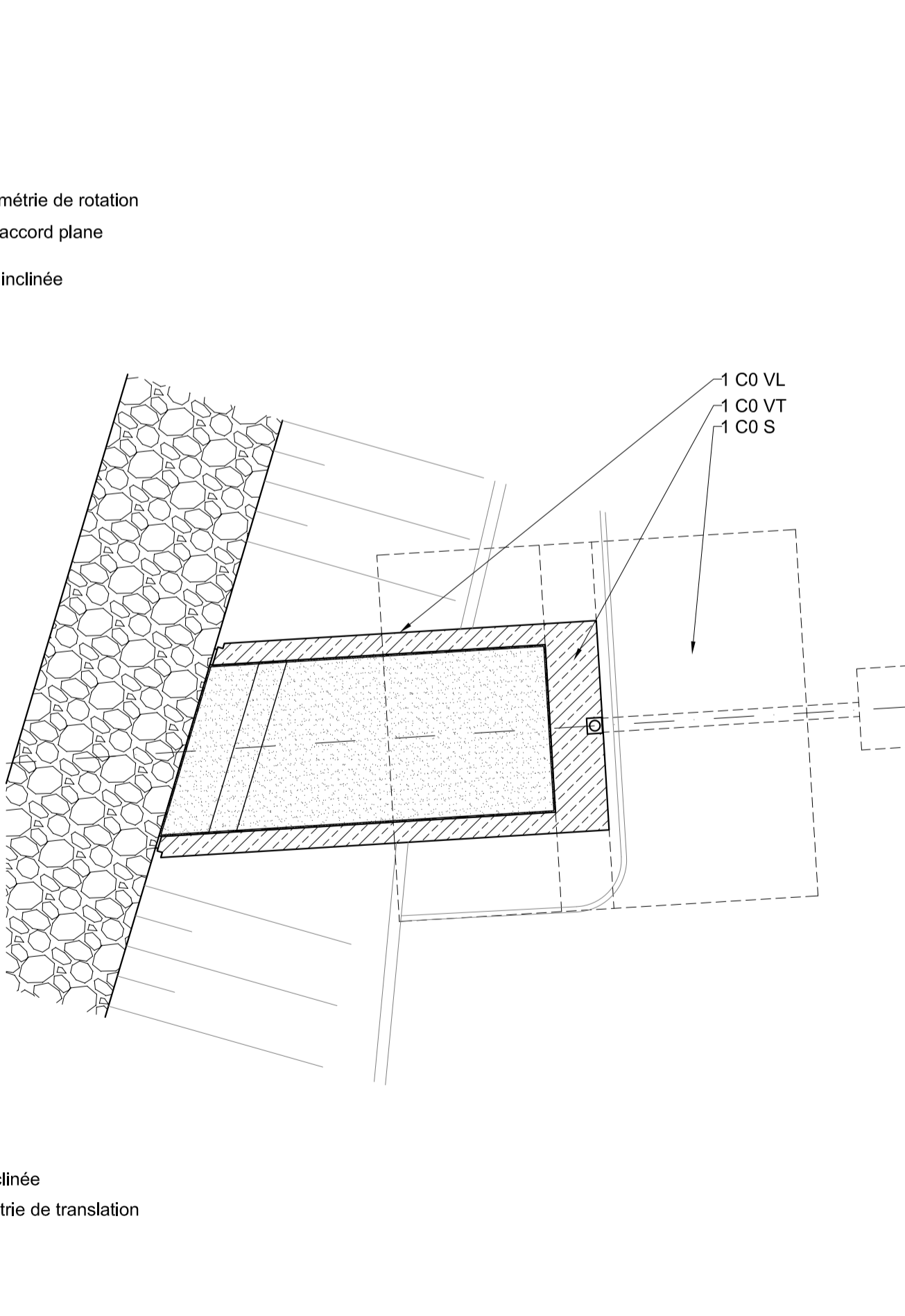

08 Plan de fondation H-H

NOMENCLATURE	Description	Matériau	Section
1 GROUPE-ŒUVRE			
T 1	Fondation P1	BA C20/27	
T 1 P 1	Semelle	BA C20/27	
T 1 P 2	Pieu	BA C20/27	
T 1 P 3	Fondation P2	BA C20/27	
T 1 P 4	Semelle	BA C20/27	
T 1 P 5	Pieu	BA C20/27	
T 1 P 6	Fondation P3	BA C20/27	
T 1 P 7	Semelle	BA C20/27	
T 1 P 8	Pieu	BA C20/27	
T 1 P 9	Fondation P4	BA C20/27	
T 1 P 10	Semelle	BA C20/27	
T 1 P 11	Pieu	BA C20/27	
T 1 P 12	Fondation PP	BA C20/27	
T 1 P 13	Semelle	BA C20/27	
T 1 P 14	Pieu	BA C20/27	
T 1 P 15	Fondation P5	BA C20/27	
T 1 P 16	Semelle	BA C20/27	
T 1 P 17	Pieu	BA C20/27	
T 1 P 18	Fondation P6	BA C20/27	
T 1 P 19	Semelle	BA C20/27	
T 1 P 20	Pieu	BA C20/27	
T 1 P 21	Fondation P7	BA C20/27	
T 1 P 22	Semelle	BA C20/27	
T 1 P 23	Pieu	BA C20/27	
T 1 P 24	Fondation P8	BA C20/27	
T 1 P 25	Semelle	BA C20/27	
T 1 P 26	Pieu	BA C20/27	
T 1 P 27	Fondation P9	BA C20/27	
T 1 P 28	Semelle	BA C20/27	
T 1 P 29	Pieu	BA C20/27	
T 1 P 30	Fondation P10	BA C20/27	
T 1 P 31	Semelle	BA C20/27	
T 1 P 32	Pieu	BA C20/27	
T 1 P 33	Fondation P11	BA C20/27	
T 1 P 34	Semelle	BA C20/27	
T 1 P 35	Pieu	BA C20/27	
T 1 P 36	Fondation P12	BA C20/27	
T 1 P 37	Semelle	BA C20/27	
T 1 P 38	Pieu	BA C20/27	
T 1 P 39	Fondation P13	BA C20/27	
T 1 P 40	Semelle	BA C20/27	
T 1 P 41	Pieu	BA C20/27	
T 1 P 42	Fondation P14	BA C20/27	
T 1 P 43	Semelle	BA C20/27	
T 1 P 44	Pieu	BA C20/27	
T 1 P 45	Fondation P15	BA C20/27	
T 1 P 46	Semelle	BA C20/27	
T 1 P 47	Pieu	BA C20/27	
T 1 P 48	Fondation P16	BA C20/27	
T 1 P 49	Semelle	BA C20/27	
T 1 P 50	Pieu	BA C20/27	
T 1 P 51	Fondation P17	BA C20/27	
T 1 P 52	Semelle	BA C20/27	
T 1 P 53	Pieu	BA C20/27	
T 1 P 54	Fondation P18	BA C20/27	
T 1 P 55	Semelle	BA C20/27	
T 1 P 56	Pieu	BA C20/27	
T 1 P 57	Fondation P19	BA C20/27	
T 1 P 58	Semelle	BA C20/27	
T 1 P 59	Pieu	BA C20/27	
T 1 P 60	Fondation P20	BA C20/27	
T 1 P 61	Semelle	BA C20/27	
T 1 P 62	Pieu	BA C20/27	
T 1 P 63	Fondation P21	BA C20/27	
T 1 P 64	Semelle	BA C20/27	
T 1 P 65	Pieu	BA C20/27	
T 1 P 66	Fondation P22	BA C20/27	
T 1 P 67	Semelle	BA C20/27	
T 1 P 68	Pieu	BA C20/27	
T 1 P 69	Fondation P23	BA C20/27	
T 1 P 70	Semelle	BA C20/27	
T 1 P 71	Pieu	BA C20/27	
T 1 P 72	Fondation P24	BA C20/27	
T 1 P 73	Semelle	BA C20/27	
T 1 P 74	Pieu	BA C20/27	
T 1 P 75	Fondation P25	BA C20/27	
T 1 P 76	Semelle	BA C20/27	
T 1 P 77	Pieu	BA C20/27	
T 1 P 78	Fondation P26	BA C20/27	
T 1 P 79	Semelle	BA C20/27	
T 1 P 80	Pieu	BA C20/27	
T 1 P 81	Fondation P27	BA C20/27	
T 1 P 82	Semelle	BA C20/27	
T 1 P 83	Pieu	BA C20/27	
T 1 P 84	Fondation P28	BA C20/27	
T 1 P 85	Semelle	BA C20/27	
T 1 P 86	Pieu	BA C20/27	
T 1 P 87	Fondation P29	BA C20/27	
T 1 P 88	Semelle	BA C20/27	
T 1 P 89	Pieu	BA C20/27	
T 1 P 90	Fondation P30	BA C20/27	
T 1 P 91	Semelle	BA C20/27	
T 1 P 92	Pieu	BA C20/27	
T 1 P 93	Fondation P31	BA C20/27	
T 1 P 94	Semelle	BA C20/27	
T 1 P 95	Pieu	BA C20/27	
T 1 P 96	Fondation P32	BA C20/27	
T 1 P 97	Semelle	BA C20/27	
T 1 P 98	Pieu	BA C20/27	
T 1 P 99	Fondation P33	BA C20/27	
T 1 P 100	Semelle	BA C20/27	
T 1 P 101	Pieu	BA C20/27	
T 1 P 102	Fondation P34	BA C20/27	
T 1 P 103	Semelle	BA C20/27	
T 1 P 104	Pieu	BA C20/27	
T 1 P 105	Fondation P35	BA C20/27	
T 1 P 106	Semelle	BA C20/27	
T 1 P 107	Pieu	BA C20/27	
T 1 P 108	Fondation P36	BA C20/27	
T 1 P 109	Semelle	BA C20/27	
T 1 P 110	Pieu	BA C20/27	
T 1 P 111	Fondation P37	BA C20/27	
T 1 P 112	Semelle	BA C20/27	
T 1 P 113	Pieu	BA C20/27	
T 1 P 114	Fondation P38	BA C20/27	
T 1 P 115	Semelle	BA C20/27	
T 1 P 116	Pieu	BA C20/27	
T 1 P 117	Fondation P39	BA C20/27	
T 1 P 118	Semelle	BA C20/27	
T 1 P 119	Pieu	BA C20/27	
T 1 P 120	Fondation P40	BA C20/27	
T 1 P 121	Semelle	BA C20/27	
T 1 P 122	Pieu	BA C20/27	
T 1 P 123	Fondation P41	BA C20/27	
T 1 P 124	Semelle	BA C20/27	
T 1 P 125	Pieu	BA C20/27	
T 1 P 126	Fondation P42	BA C20/27	
T 1 P 127	Semelle	BA C20/27	
T 1 P 128	Pieu	BA C20/27	
T 1 P 129	Fondation P43	BA C20/27	
T 1 P 130	Semelle	BA C20/27	
T 1 P 131	Pieu	BA C20/27	
T 1 P 132	Fondation P44	BA C20/27	
T 1 P 133	Semelle	BA C20/27	
T 1 P 134	Pieu	BA C20/27	
T 1 P 135	Fondation P45	BA C20/27	
T 1 P 136	Semelle	BA C20/27	
T 1 P 137	Pieu	BA C20/27	
T 1 P 138	Fondation P46	BA C20/27	
T 1 P 139	Semelle	BA C20/27	
T 1 P 140	Pieu	BA C20/27	
T 1 P 141	Fondation P47	BA C20/27	
T 1 P 142	Semelle	BA C20/27	
T 1 P 143	Pieu	BA C20/27	
T 1 P 144	Fondation P48	BA C20/27	
T 1 P 145	Semelle	BA C20/27	
T 1 P 146	Pieu	BA C20/27	
T 1 P 147	Fondation P49	BA C20/27	
T 1 P 148	Semelle	BA C20/27	
T 1 P 149	Pieu	BA C20/27	
T 1 P 150	Fondation P50	BA C20/27	
T 1 P 151	Semelle	BA C20/27	
T 1 P 152	Pieu	BA C20/27	
T 1 P 153	Fondation P51	BA C20/27	
T 1 P 154	Semelle	BA C20/27	
T 1 P 155	Pieu	BA C20/27	
T 1 P 156	Fondation P52	BA C20/27	
T 1 P 157	Semelle	BA C20/27	
T 1 P 158	Pieu	BA C20/27	
T 1 P 159	Fondation P53	BA C20/27	
T 1 P 160	Semelle	BA C20/27	
T 1 P 161	Pieu	BA C20/27	
T 1 P 162	Fondation P54	BA C20/27	
T 1 P 163	Semelle	BA C20/27	
T 1 P 164	Pieu	BA C20/27	
T 1 P 165	Fondation P55	BA C20/27	
T 1 P 166	Semelle	BA C20/27	
T 1 P 167	Pieu	BA C20/27	
T 1 P 168	Fondation P56	BA C20/27	
T 1 P 169	Semelle	BA C20/27	
T 1 P 170	Pieu	BA C20/27	
T 1 P 171	Fondation P57	BA C20/27	
T 1 P 172	Semelle	BA C20/27	
T 1 P 173	Pieu	BA C20/27	
T 1 P 174	Fondation P58	BA C20/27	
T 1 P 175	Semelle	BA C20/27	
T 1 P 176	Pieu	BA C20/27	
T 1 P 177	Fondation P59	BA C20/27	
T 1 P 178	Semelle	BA C20/27	
T 1 P 179	Pieu	BA C20/27	
T 1 P 180	Fondation P60	BA C20/27	
T 1 P 181	Semelle	BA C20/27	
T 1 P 182	Pieu	BA C20/27	
T 1 P 183	Fondation P61	BA C20/27	
T 1 P 184	Semelle	BA C20/27	
T 1 P 185	Pieu	BA C20/27	
T 1 P 186	Fondation P62	BA C20/27	
T 1 P 187	Semelle	BA C20/27	
T 1 P 188	Pieu	BA C20/27	
T 1 P 189	Fondation P63	BA C20/27	
T 1 P 190	Semelle	BA C20/27	
T 1 P 191	Pieu	BA C20/27	
T 1 P 192	Fondation P64	BA C20/27	
T 1 P 193	Semelle	BA C20/27	
T 1 P 194	Pieu	BA C20/27	
T 1 P 195	Fondation P65	BA C20/27	
T 1 P 196	Semelle	BA C20/27	
T 1 P 197	Pieu	BA C20/27	
T 1 P 198	Fondation P66	BA C20/27	
T 1 P 199	Semelle	BA C20/27	
T 1 P 200	Pieu	BA C20/27	
T 1 P 201	Fondation P67	BA C20/27	
T 1 P 202	Semelle	BA C20/27	
T 1 P 203	Pieu	BA C20/27	
T 1 P 204	Fondation P68	BA C20/27	
T 1 P 205	Semelle	BA C20/27	
T 1 P 206	Pieu	BA C20/27	
T 1 P 207	Fondation P69	BA C20/27	
T 1 P 208	Semelle	BA C20/27	
T 1 P 209	Pieu	BA C20/27	
T 1 P 210	Fondation P70	BA C20/27	
T 1 P 211	Semelle	BA C20/27	
T 1 P 212	Pieu	BA C20/27	
T 1 P 213	Fondation P71	BA C20/27	
T 1 P 214	Semelle	BA C20/27	
T 1 P 215	Pieu	BA C20/27	
T 1 P 216	Fondation P72	BA C20/27	
T 1 P 217	Semelle	BA C20/27	
T 1 P 218	Pieu	BA C20/27	
T 1 P 219	Fondation P73	BA C20/27	
T 1 P 220	Semelle	BA C20/27	
T 1 P 221	Pieu	BA C20/27	
T 1 P 222	Fondation P74	BA C20/27	
T 1 P 223	Semelle	BA C20/27	
T 1 P 224	Pieu	BA C20/27	
T 1 P 225	Fondation P75	BA C20/27	
T 1 P 226	Semelle	BA C20/27	
T 1 P 227	Pieu	BA C20/27	
T 1 P 228	Fondation P76	BA C20/27	
T 1 P 229	Semelle	BA C20/27	
T 1 P 230	Pieu	BA C20/27	
T 1 P 231	Fondation P77	BA C20/27	
T 1 P 232	Semelle	BA C20/27	
T 1 P 233	Pieu	BA C20/27	
T 1 P 234	Fondation P78	BA C20/27	
T 1 P 235	Semelle	BA C20/27	
T 1 P 236	Pieu	BA C20/27	
T 1 P 237			